

VBB/VBS Series Ball Valve Assemblies



Application

The DuraDrive VBB and VBS Series valves are Two-Way or Three-way, 1/2" or 3/4" (15 mm or 20 mm), characterized ball valves. The M1 and M2 series actuators are direct coupled to the VBB/VBS series valves and accept two-position, floating or proportional control signals from a DDC system, controller, or thermostat for control of hot or chilled water, or solutions of up to 60% glycol.

Typical applications include VAV reheat, fan coil units, hot and chilled water coils in air handling units, heat pumps and unit ventilators.

Applicable Literature

- DuraDrive VBB and VBS Series Two-position Spring-Return Ball Valves Installation Instructions, F-27392.
- DuraDrive VBB and VBS Series Floating Spring Return and Non-spring Return Ball Valves Installation Instructions, F-27393.
- DuraDrive VBB and VBS Series Proportional Spring Return and Non-spring Return Ball Valves Installation Instructions, F-27394.
- DuraDrive VBB and VBS Series Brochure , F-27681.
- EN-205 Water System Guidelines, F-26080.
- EN-206 Guidelines for Powering Multiple Actuators, F-26363.
- Valve Products Catalog, F-27414.

Features

- Easy product selection — all actuators fit all valve bodies.
- Fast, easy actuator installation — no linkage or tools required.
- Flow characterizing insert provides equal percentage flow characteristic for stable, accurate floating and proportional control.
- ANSI IV seat leakage (0.01%) for both Two-Way and Three-way valves (A and B port).
- Brass and stainless steel trim models.
- Cvs from 0.3 to 10.
- Normally open, normally closed, and non-spring return assemblies available.
- Two-position, Floating or Proportional (0 to 5 Vdc, 0 to 10 Vdc, 5 to 10 Vdc, or 4 to 20 mAdc, jumper selectable)
- Proportional actuator is direct or reverse acting, jumper selectable.
- RoHS Compliant (VBS Assemblies)
- Reach Compliant

EPRI Edgemont Precision Rebuilders, Inc
Matlack Industrial Center
207 Carter Dr Unit C
West Chester, PA 19382
800-356-3774

Schneider
Electric

[DuraDrive] VBB/VBS Series Ball Valve Assemblies

Specifications

Actuator

Voltage 24 Vac +20%, -15% @ 50/60 Hz.
 Power Requirements See Table-1, Table-2 and Table-3.
 Control Signal 2-Position, Floating or Proportional; half wave rectified power supply
 Timing, Full Open to Full Close See Table-1, Table-2 and Table-3.
 Manual Operating Lever/Position Indicator . . Stand-ard on all models.
 Auxiliary End Switch (optional) SPST 24 Vac/Vdc, 101 mA to 5 A max.
 Materials Thermoplastic base and cover. Approved for use in air plenums.
 Shipping & Storage Temperature Limit . -40 to 169 °F (-40 to 76°C).
 Operating Temperature Limit at max fluid temp.
 Floating 32 to 140 °F (0 to 60 °C)
 Proportional 32 to 140 °F (0 to 60 °C)
 Two-Position 32 to 169 °F (0 to 76°C)
 Humidity 5 to 95% relative humidity, non-condensing.
 Locations NEMA 2, IEC IP31. Indoor Use Only.

Valve

Service^a . . Hot and chilled water, up to 60% glycol.
 System Static Pressure Limit . . 600 psi (4137 kPa).
 Fluid Temperature Limit . .20 to 250°F (-7 to 121°C).
 Cv (Kv) . See Table-4, Table-5, Table-6, and Table-7.
 Close-off Pressure^b 130 psi, Two-Way; 70 psi, Three-Way
 Differential Pressure 30 psi normal operation, 20 psi quiet operation.
 Seat Leakage ANSI class IV (0.01%) at both A and B ports with pressure at inlet.
 End Connections NPT threaded (VBxxNxx) and Rp threaded (VBxxRxx).
 Rangeability Greater than 300:1.
 Body Material Forged brass.
 Stem Material Stainless steel anti-blow out stem with dual Viton™ o-rings.
 Ball Material . . Chrome plated brass (VBB series) or stainless steel (VBS series).
 Seat Material PTFE.
 Characterized Insert Glass-filled PEEK.

a. Not rated for steam service.
 b. Close-off is defined as the maximum allowable pressure drop to which a valve may be subjected while fully closed.

Agency Listings

UL873 (Actuator)	Underwriters Laboratories (File #E9429 Temperature Indicating and Regulating Equipment).
cULus (Actuator)	Listed for use in Canada by Underwriters Laboratories. Canadian Standards C22.2 No. 24.
European Community	EMC Directive M1 (89/336/EEC), M2 (2004/108/EC). Low Voltage Directive (72/23/EEC).
Australia	This product meets requirements to bear the C-Tick Mark according to the terms specified by the Communications Authority under the Radio Communications Act of 1992.
Plenum Rating	Actuators with terminal block or plenum cable leads are plenum rated per UL file number E9429.
CRN Number	#OCO970.9087TN.
RoHS Compliant	VBS valves and M1/M2 actuators comply with European Directive 2002/95. Please consult factory for part number specific compliance.
REACH Compliant	Compliant as defined in Article 33 of the REACH regulation No. 1907/2006.

Application Drawing

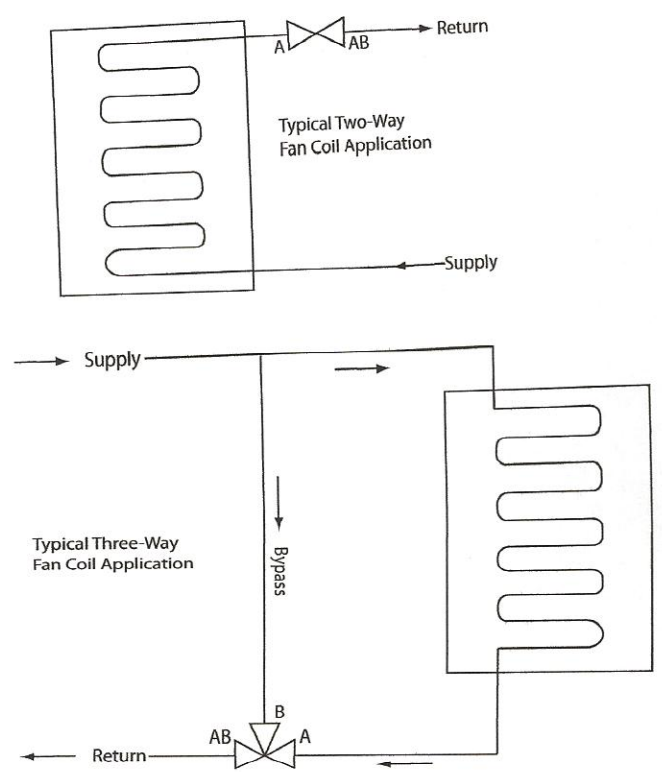

Note: Typical applications. For simplicity, balancing valves and control devices not shown.

[DuraDrive] VBB/VBS Series Ball Valve Assemblies

Product Selection: Actuators

Table-1 Two-Position Actuators

Part Number	Control Signal	Spring Return Action (Valve Normal Position)	VA @ 24 Vac/24Vdc	Leads	Stroke Time ^a	Spring Return Time ^a	End Switch
M210A00	Two-Position	Normally Open	3.5/1.8	Removable Terminal Block ^b	50 sec.	35 sec.	SPST
M210A01				10 ft. (3.05 m) Plenum Cable ^c			
M210A11				10 ft. (3.05 m) Plenum Cable ^c			
M210A02				18 in. (45 cm) Appliance Wire			
M210A12				18 in. (45 cm) Appliance Wire			
M220A00				Removable Terminal Block ^b			
M220A01		10 ft. (3.05 m) Plenum Cable ^c		SPST			
M220A11		10 ft. (3.05 m) Plenum Cable ^c					
M220A02		18 in. (45 cm) Appliance Wire					
M220A12		Normally Closed					18 in. (45 cm) Appliance Wire
							18 in. (45 cm) Appliance Wire

Table-2 Floating Actuators

Part Number	Control Signal	Spring Return Action (Valve Normal Position)	VA @ 24 Vac 50/60 Hz	Leads	Stroke Time, sec. 50/60 Hz	Time-out Delay, sec. 50/60 Hz
M131A00	Floating	None	2.3/2.4	Terminal Block ^b	159/135	N/A ^f
M131A01				10 ft. (3.05 m) Plenum Cable ^c		
M132A00			2.5/2.5	Terminal Block ^b		
M132A01				10 ft. (3.05 m) Plenum Cable ^c		
M112A00		Normally Open	3.2/3.3 ^d	Terminal Block ^b		217/181
M112A01				10 ft. (3.05 m) Plenum Cable ^c		
M122A00			Normally Closed	Terminal Block ^b		
M122A01				10 ft. (3.05 m) Plenum Cable ^c		

Table-3 Proportional Actuators

Part Number	Control Signal	Spring Return Action (Valve Normal Position)	VA @ 24 Vac 50/60 Hz	Leads	Stroke Time, sec. 50/60 Hz	Time-out Delay, sec. 50/60 Hz
M133A00	Proportional ^a (0 to 5 Vdc, 0 to 10 Vdc, 5 to 10 Vdc, 4 to 20 mA ^{dc} *)	None	2.7/2.8	Terminal Block ^b	159/135	200/166
M133A01				10 ft. (3.05 m) Plenum Cable ^c		
M113A00		Normally Open	2.7/2.8 ^d	Terminal Block ^b		
M113A01				10 ft. (3.05 m) Plenum Cable ^c		
M123A00		Normally Closed		Terminal Block ^b		
M123A01				10 ft. (3.05 m) Plenum Cable ^c		

- a. Jumper selectable. Default configured for 0 to 10 Vdc input signal, direct acting control.
- b. All terminal block and appliance wire units accept a 1/2" (12.7 mm) conduit connector fitting (.875" diameter (22.2 mm)).
- c. All plenum cable units include an integral 3/8" (9.5 mm) conduit connector fitting.
- d. Size transformer for 10 VA per actuator.
- e. For 4 to 20 mA control, a separate isolated transformer must be used with each valve.
- f. No time-out feature. Controller must provide time-out after three minutes.
- g. Nominal.

[DuraDrive] VBB/VBS Series Ball Valve Assemblies

Product Selection: Brass Trim Valves

Table-4 Two-Way Brass Trim Valve Bodies

Size	Part Number	End Connection	Cv (Kv)	Size	Part Number	End Connection	Cv (Kv)
1/2"	VBB2N00	NPT	0.3 (0.3)	15 mm (Rp 1/2)	VBB2R00	Rp ^a	0.3 (0.3)
	VBB2N01		0.7 (0.6)		VBB2R01		0.7 (0.6)
	VBB2N02		1.2 (1.0)		VBB2R02		1.2 (1.0)
	VBB2N03		2.1 (1.8)		VBB2R03		2.1 (1.8)
	VBB2N04		3.5 (3.0)		VBB2R04		3.5 (3.0)
	VBB2N05		4.7 (4.1)		VBB2R05		4.7 (4.1)
	VBB2N06		7.7 (6.7)		VBB2R06		7.7 (6.7)
	VBB2N07 ^b		10 (8.7)		VBB2R07 ^b		10 (8.7)
	VBB2N10		0.3 (0.3)		VBB2R10		0.3 (0.3)
	VBB2N11		0.7 (0.6)		VBB2R11		0.7 (0.6)
3/4"	VBB2N12	NPT	1.2 (1.0)	20 mm (Rp 3/4)	VBB2R12	Rp ^a	1.2 (1.0)
	VBB2N13		2.1 (1.8)		VBB2R13		2.1 (1.8)
	VBB2N14		3.5 (3.0)		VBB2R14		3.5 (3.0)
	VBB2N15		4.7 (4.1)		VBB2R15		4.7 (4.1)
	VBB2N16		7.7 (6.7)		VBB2R16		7.7 (6.7)
	VBB2N17 ^b		10 (8.7)		VBB2R17 ^b		10 (8.7)

a. Metric Pipe Thread-Female

b. Full Port Model without characterized disc.

Table-5 Three-Way Brass Trim Valve Bodies

Size	Part Number	End Connection	Cv (Kv) A Port	Cv (Kv) B Port	Size	Part Number	End Connection	Cv (Kv) A Port	Cv (Kv) B Port
1/2"	VBB3N00	NPT	0.3 (0.3)	0.3 (0.3)	15 mm (Rp 1/2)	VBB3R00	Rp ^a	0.3 (0.3)	0.3 (0.3)
	VBB3N01		0.6 (0.5)	0.8 (0.7)		VBB3R01		0.6 (0.5)	0.8 (0.7)
	VBB3N02		1.0 (.85)	0.8 (0.7)		VBB3R02		1.0 (.85)	0.8 (0.7)
	VBB3N03		2.0 (1.7)	1.5 (1.3)		VBB3R03		2.0 (1.7)	1.5 (1.3)
	VBB3N04		3.0 (2.6)	1.5 (1.3)		VBB3R04		3.0 (2.6)	1.5 (1.3)
	VBB3N05		4.5 (3.9)	2.7 (2.3)		VBB3R05		4.5 (3.9)	2.7 (2.3)
	VBB3N06		7.3 (6.3)	4.1 (3.5)		VBB3R06		7.3 (6.3)	4.1 (3.5)
	VBB3N07 ^b		10.0 (8.7)	4.8 (4.1)		VBB3R07 ^b		10.0 (8.7)	4.8 (4.1)
	VBB3N10		0.3 (0.3)	0.3 (0.3)		VBB3R10		0.3 (0.3)	0.3 (0.3)
	VBB3N11		0.6 (0.5)	0.8 (0.7)		VBB3R11		0.6 (0.5)	0.8 (0.7)
3/4"	VBB3N12	NPT	1.0 (.85)	0.8 (0.7)	20 mm (Rp 3/4)	VBB3R12	Rp ^a	1.0 (.85)	0.8 (0.7)
	VBB3N13		2.0 (1.7)	1.5 (1.3)		VBB3R13		2.0 (1.7)	1.5 (1.3)
	VBB3N14		3.0 (2.6)	1.5 (1.3)		VBB3R14		3.0 (2.6)	1.5 (1.3)
	VBB3N15		4.5 (3.9)	2.7 (2.3)		VBB3R15		4.5 (3.9)	2.7 (2.3)
	VBB3N16		7.3 (6.3)	4.1 (3.5)		VBB3R16		7.3 (6.3)	4.1 (3.5)
	VBB3N17 ^b		10.0 (8.7)	4.8 (4.1)		VBB3R17 ^b		10.0 (8.7)	4.8 (4.1)

a. Metric Pipe Thread-Female

b. Full Port Model without characterized disc.

Application Note for Two-Way and Three-way Valves

The VBB/VBS Series Ball Valves are Characterized Control Ball Valves. They are designed so that flow thru the A-port exhibits equal percentage flow (see Page 10). Thus, the A-port is the control port.

In a Three-way valve, the B-port is the bypass port. Flow thru the B-port is designed to be less than that of the A-port. In most applications, this reduced flow compensates for the pressure drop that is seen by the coil supplied by the A-port.

[DuraDrive] VBB/VBS Series Ball Valve Assemblies

Product Selection: Stainless Steel Trim Valves

Table-6 Two-Way Stainless Steel Trim Valve Bodies

Size	Part Number	End Connection	Cv (Kv)	Size	Part Number	End Connection	Cv (Kv)
1/2"	VBS2N00	NPT	0.3 (0.3)	15 mm (Rp 1/2)	VBS2R00	Rp ^a	0.3 (0.3)
	VBS2N01		0.7 (0.6)		VBS2R01		0.7 (0.6)
	VBS2N02		1.2 (1.0)		VBS2R02		1.2 (1.0)
	VBS2N03		2.1 (1.8)		VBS2R03		2.1 (1.8)
	VBS2N04		3.5 (3.0)		VBS2R04		3.5 (3.0)
	VBS2N05		4.7 (4.1)		VBS2R05		4.7 (4.1)
	VBS2N06		7.7 (6.7)		VBS2R06		7.7 (6.7)
	VBS2N07 ^b		10 (8.7)		VBS2R07 ^b		10 (8.7)
	3/4"		VBS2N10		0.3 (0.3)		20 mm (Rp 3/4)
VBS2N11			0.7 (0.6)	VBS2R11	0.7 (0.6)		
VBS2N12			1.2 (1.0)	VBS2R12	1.2 (1.0)		
VBS2N13			2.1 (1.8)	VBS2R13	2.1 (1.8)		
VBS2N14			3.5 (3.0)	VBS2R14	3.5 (3.0)		
VBS2N15			4.7 (4.1)	VBS2R15	4.7 (4.1)		
VBS2N16			7.7 (6.7)	VBS2R16	7.7 (6.7)		
VBS2N17 ^b			10 (8.7)	VBS2R17 ^b	10 (8.7)		

a. Metric Pipe Thread-Female

b. Full Port Model without characterized disc.

Table-7 Three-Way Stainless Steel Trim Valve Bodies

Size	Part Number	End Connection	Cv (Kv) A Port	Cv (Kv) B Port	Size	Part Number	End Connection	Cv (Kv) A Port	Cv (Kv) B Port
1/2"	VBS3N00	NPT	0.3 (0.3)	0.3 (0.3)	15 mm (Rp 1/2)	VBS3R00	Rp ^a	0.3 (0.3)	0.3 (0.3)
	VBS3N01		0.6 (0.5)	0.8 (0.7)		VBS3R01		0.6 (0.5)	0.8 (0.7)
	VBS3N02		1.0 (.85)	0.8 (0.7)		VBS3R02		1.0 (.85)	0.8 (0.7)
	VBS3N03		2.0 (1.7)	1.5 (1.3)		VBS3R03		2.0 (1.7)	1.5 (1.3)
	VBS3N04		3.0 (2.6)	1.5 (1.3)		VBS3R04		3.0 (2.6)	1.5 (1.3)
	VBS3N05		4.5 (3.9)	2.7 (2.3)		VBS3R05		4.5 (3.9)	2.7 (2.3)
	VBS3N06		7.3 (6.3)	4.1 (3.5)		VBS3R06		7.3 (6.3)	4.1 (3.5)
	VBS3N07 ^b		10.0 (8.7)	4.8 (4.1)		VBS3R07 ^b		10.0 (8.7)	4.8 (4.1)
3/4"	VBS3N10		0.3 (0.3)	0.3 (0.3)	20 mm (Rp 3/4)	VBS3R10		0.3 (0.3)	0.3 (0.3)
	VBS3N11		0.6 (0.5)	0.8 (0.7)		VBS3R11		0.6 (0.5)	0.8 (0.7)
	VBS3N12		1.0 (.85)	0.8 (0.7)		VBS3R12		1.0 (.85)	0.8 (0.7)
	VBS3N13		2.0 (1.7)	1.5 (1.3)		VBS3R13		2.0 (1.7)	1.5 (1.3)
	VBS3N14		3.0 (2.6)	1.5 (1.3)		VBS3R14		3.0 (2.6)	1.5 (1.3)
	VBS3N15		4.5 (3.9)	2.7 (2.3)		VBS3R15		4.5 (3.9)	2.7 (2.3)
	VBS3N16		7.3 (6.3)	4.1 (3.5)		VBS3R16		7.3 (6.3)	4.1 (3.5)
	VBS3N17 ^b		10.0 (8.7)	4.8 (4.1)		VBS3R17 ^b		10.0 (8.7)	4.8 (4.1)

a. Metric Pipe Thread-Female

b. Full Port Model without characterized disc.

EPRI Edgemont Precision Rebuilders, Inc
 Matlack Industrial Center
 207 Carter Dr Unit C
 West Chester, PA 19382
 800-356-3774

[DuraDrive] VBB/VBS Series Ball Valve Assemblies

Ball Valve Assembly Selection Procedure

1. Select the actuator. When selecting a ball valve assembly, you must know the control signal type and voltage to first select an actuator. Consult page 3 for the following tables: Table-1 covers two-position actuator specifications and model numbers, Table-2 covers floating actuator specifications and model numbers and Table-3 covers proportional actuator specifications and model numbers.
2. Select the valve body. The valve body model number is selected based on the line size (1/2" or 3/4", 15 mm or 20 mm), ball material trim, and flow coefficient (Cv/Kv) required. Consult Table-4 and Table-5 on page 4 for brass trim valve body specifications and model numbers and Table-6 and Table-7 on page 5 for stainless steel trim valve body specifications and model numbers. See "Flow Coefficient Selection" on page 10 for information in determining the flow coefficient.

Other considerations.

3. General service conditions: Make sure the actuator is suitable for the anticipated ambient conditions and that the valve body is compatible with the system fluid temperature and pressure requirements.
4. Close-off pressure: Confirm that the VBB/VBS ball valve's close off rating is suitable for the valve control application.
5. Space requirements: If mounting space limitations are a consideration, check the actuator/valve assembly dimensions on page 8.
6. Pipe reducers: Refer to Tables on page 11 for estimating effective Cvs when using pipe reducers.
7. Ordering information. You may order the actuator and valve body separately or as a factory assembly. To order a complete valve and actuator assembly, specify the valve body part number and the actuator part number separated by a "+."
8. Example: To order actuator valve body VBB2N15 and M112A00 as a factory valve/actuator assembly, specify VBB2N15+M112A00.

Flow Direction

A notch cut into the stem indicator at the tip of the valve stem is an external indicator of where the closed portion of the ball sits internally.

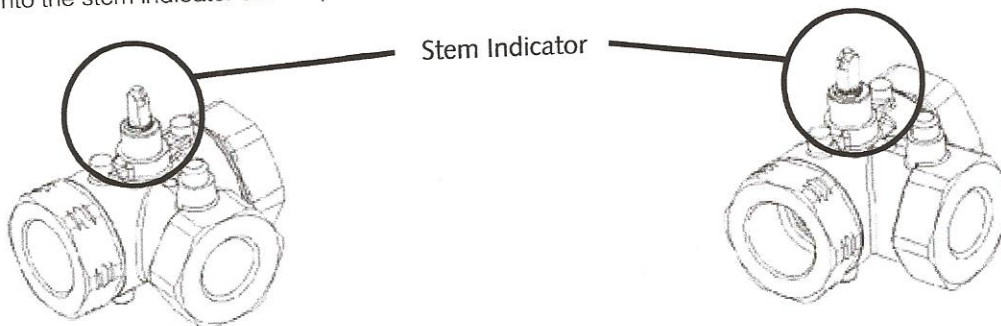

In the drawings below, the black mark on the stem indicator represents this stem notch.

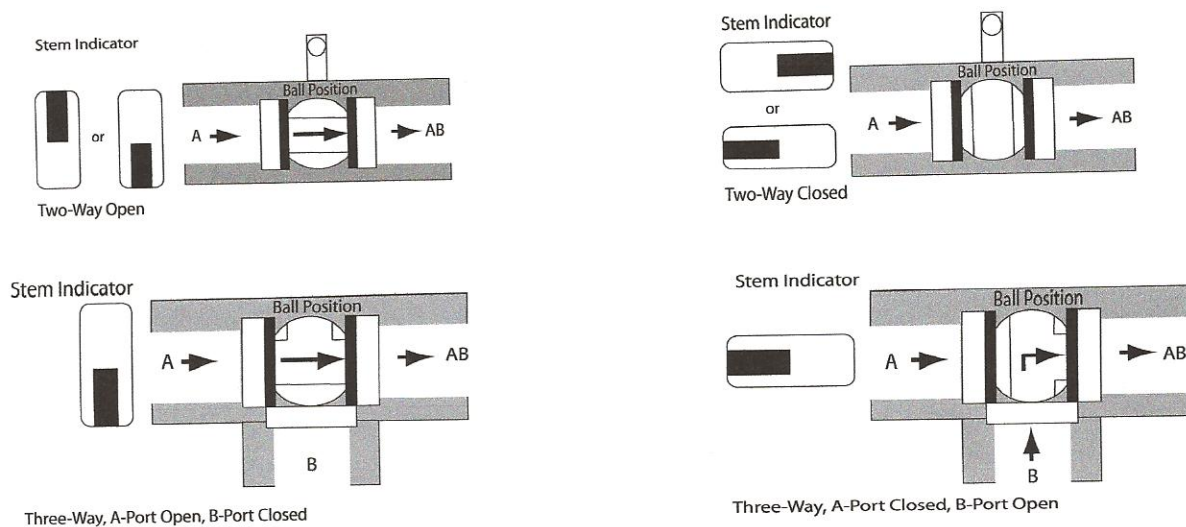

Application Notes

The DuraDrive VBB/VBS Series Ball Valves are valve actuator assemblies designed to make incremental adjustments to flow based on the control signal input. The actuators are not intended for continuous use in zero dead band control systems.

Two-Position Spring Return Actuators

When powered, the actuator moves to the desired position, winding the spring return system. When power is removed, the spring returns the actuator to the normal position. Two position spring return actuators can be purchased with an optional built-in auxiliary SPST end switch for interfacing or signaling; for example, zone pump burner control. Do not use the manual operator while power is applied to the actuator. Manual positioning of the actuator while power is applied is NOT recommended.

Floating/Proportional Spring Return Actuators:

When power is applied to the actuator, there is a 3-second delay before the solenoid latches and the gear train is engaged. Upon power loss, the solenoid releases after 2 seconds, allowing the actuator to spring return to normal position. This prevents the loss of valve position during brief outages. The spring return feature should not be used for routine, normal operation.

Proportional Spring Return and Non-Spring Return Actuators:

The control signal input and action is selected by means of the input signal jumper on the actuator circuit board. All actuators are shipped with the input signal jumper set for a 0 to 10 Vdc control signal and the control action jumper set for direct action (DA; valves opens with increasing control signal). Multiple actuators may be connected to a single controller. Do not exceed the maximum current draw of the controller or transformer. When using a 4 to 20 mA dc control signal, a separate isolation transformer must be used with each actuator.

Proportional Actuators perform a self-calibration cycle on power-up. The actuator will run to the open direction for approximately 20 seconds and then closed direction for approximately 2 1/2 min (60 Hz) or 3 1/2 min (50Hz). See Table-2 for exact timing. Once this cycle is complete, the actuator will then accept and respond to the control signal.

Manual positioning of the actuator while power is applied is NOT recommended. If the actuator is manually positioned while power is applied, the calibration cycle will need to be completed again for the actuator to function properly. To recalibrate the actuator, cycle power off for more than 6 seconds.

Floating Spring Return and Non-Spring Return Actuators:

Spring Return and Non-Spring Return actuators with time-out will automatically limit the running time of the actuator. The time-out feature automatically cuts off the control signal to the valve after three minutes (see Table-1) of continuous operation. Upon change in control signal direction, the actuator will resume operation. The controller or thermostat used to operate the Non-Spring Return Floating actuator without timeout must be configured to turn off the control signal after being continuously on for three minutes. Multiple actuators may be connected to a single controller. Do not exceed the maximum current draw of the controller or transformer.

Power/Failure Action

	Control Signal	Position upon loss of power		
		Non-Spring Return Actuator	Spring Return Open Actuator - Fail Open	Spring Return Closed Actuator - Fail Closed
Floating	Power to "Open" terminal will open A to AB	Maintain last position	Will spring A to AB open	Will spring A to AB closed
Proportional	DA jumpered - increase in control signal will open A to AB	Maintain last position	Will spring A to AB open	Will spring A to AB closed
	RA jumpered - increase in control signal will close A to AB	Maintain last position	Will spring A to AB open	Will spring A to AB closed
	Control Signal	Spring Return Open Actuator	Spring Return Closed Actuator	
2-Position	Power On	A to AB Closed	A to AB Open	
	Power Off	A to AB Open	A to AB Closed	

* Two-Way valve operation described. For a Three-way valve, A to AB operation is the same. B to AB operation is opposite that of A to AB operation.

[DuraDrive] VBB/VBS Series Ball Valve Assemblies

Dimensions

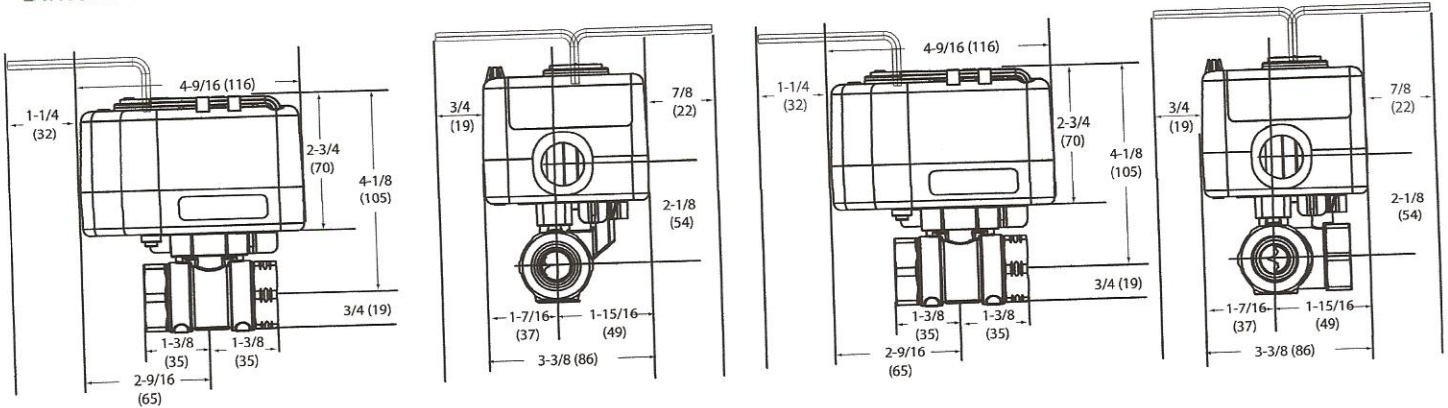

Two-Way Spring Return Two Position Assembly
Shipping Weight: 2.8 lbs (1270 g)

Three-Way Spring Return Two Position Assembly
Shipping Weight: 3.0 lbs (1360 g)

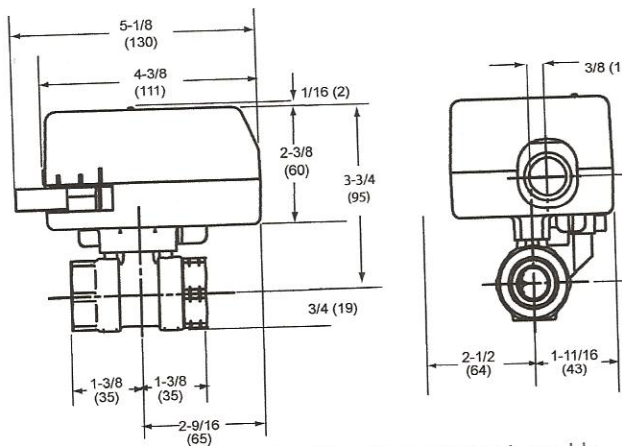

Two-Way Floating/Proportional Non-Spring Return Assembly
Shipping Weight: 2.2 lbs (998 g)

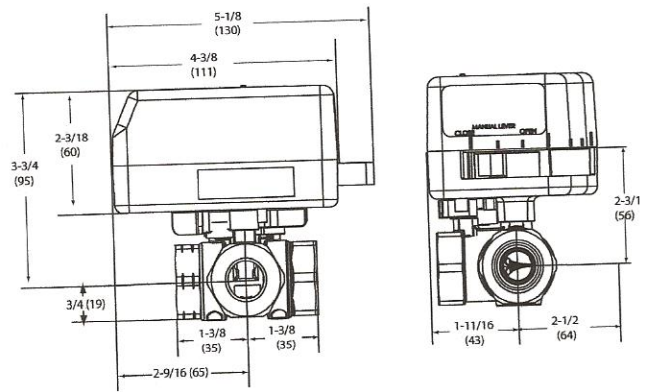

Three-Way Floating/Proportional Non-Spring Return Assembly
Shipping Weight: 2.4 lbs (1089 g)

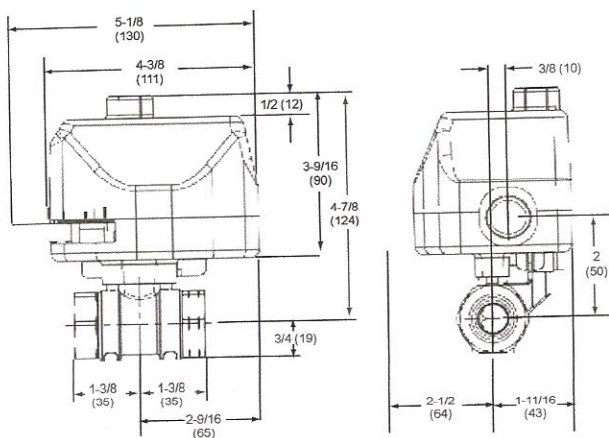

Two-Way Spring Return Floating/Proportional Spring Return Assembly
Shipping Weight: 2.4 lbs (1089 g)

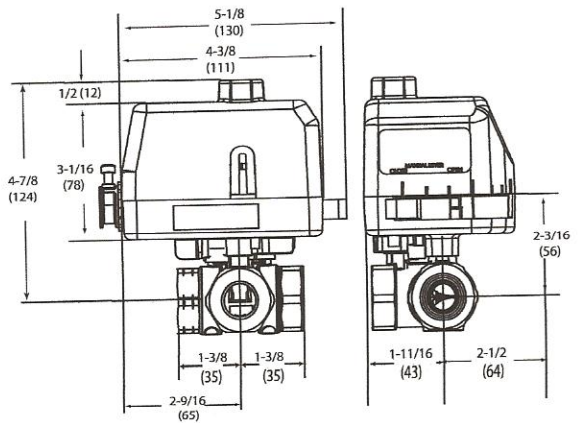

Three-Way Floating/Proportional Spring Return Assembly
Shipping Weight: 2.6 lbs (1180 g)

All dimensions shown in inches (mm) format and are rounded to the nearest 1/16".
An additional 1 in (25 mm) is required to remove the actuator from the valve.

[DuraDrive] VBB/VBS Series Ball Valve Assemblies

Cavitation limits on valve pressure drop

A valve selected with a pressure drop that is too high can cause erosion or wire drawing of the flow characterizing insert. In addition, cavitation can cause noise, damage to the valve trim (and possibly the valve body), and choke flow through the valve. Do not exceed the maximum differential pressure drop for the valve selected.

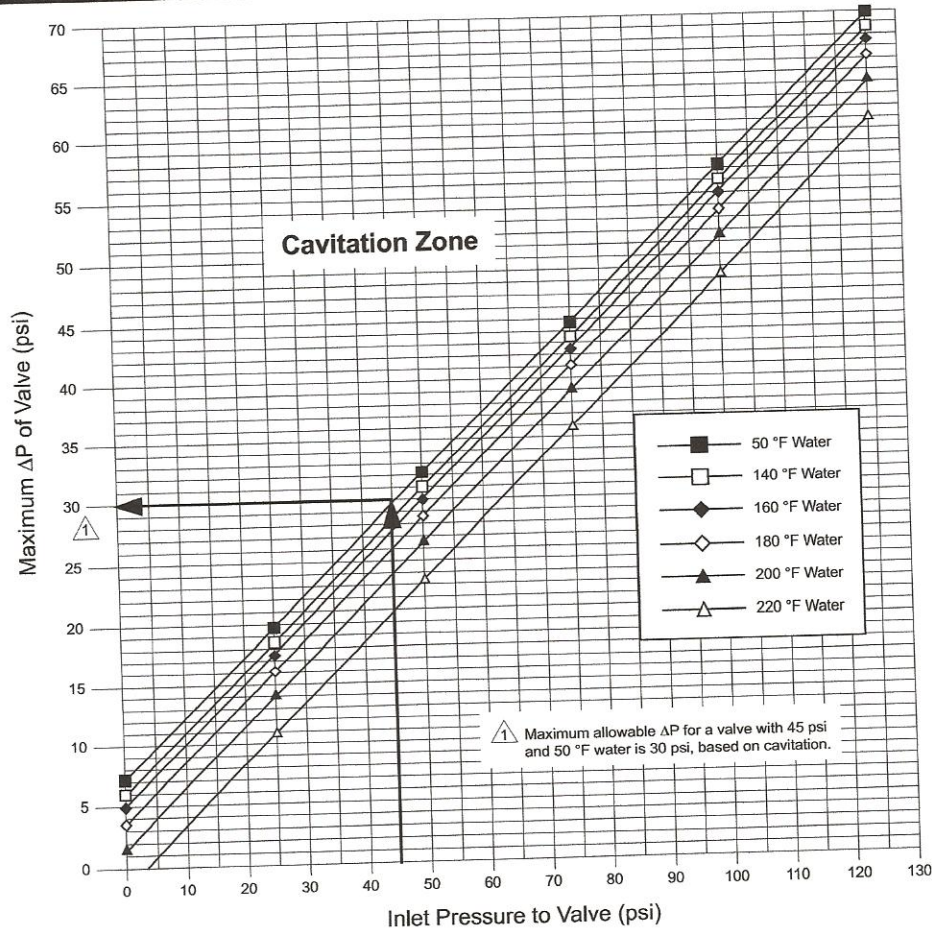

Pressure Drop Selection

Modulating control valves are usually selected to take a pressure drop of at least 50% of the "available pressure." As "available pressure" is often difficult to calculate, the normal procedure is to select a valve using a pressure drop at least equal to that in the coil or other load being controlled (except where small booster pumps are used) with a minimum pressure drop of at least 5 psi (34 kPa). When the design temperature drop is less than 60°F (33°C) for conventional heating systems, higher pressure drops across the valve are needed for good results (see below).

Pressure Drop

Design Temperature Load Drop °F (°C)	Recommended Pressure Drop (% of available pressure)	Multiplier on Load Drop
60 (33) or more	50%	1 x Load Drop
40 (22)	69%	2 x Load Drop
20 (11)	70%	3 x Load Drop

[DuraDrive] VBB/VBS Series Ball Valve Assemblies

Flow Coefficient Selection

When sizing a valve, you must select a flow coefficient (Cv), which is defined as the flow rate in U. S. gallons per minute (GPM) of 60 °F water that will pass through a fully open valve with 1 psi pressure drop (ΔP ; $k_v = m^3/h$ with a 1 bar ΔP). It is calculated using the formula:
 $C_v = GPM / (\sqrt{\Delta P})$ (ΔP is in psi) or $K_v = (m^3/h) / (\sqrt{\Delta P})$ (ΔP is in bar)

Since the flow rate through the heat exchanger is usually specified, the only variable normally available in sizing a valve is the pressure drop. The following information can be used to determine what pressure drop to use in calculating a valve Cv. Once you have determined the Cv, consult Table-4, Table-5, Table-6 and Table-7 on pages four and five to select the valve body having the nearest Cv.

Two and Three-way Valve GPM Chart

Valve Differential Pressure (P)	Both	Three-way	Two-Way	Three-way	Two-Way	Three-way	Two-Way	Three-way	Two-Way	Three-way	Two-Way	Three-way	Two-Way	Both
	0.3 Cv	0.6 Cv	0.7 Cv	1.0 Cv	1.2 Cv	2.0 Cv	2.1 Cv	3.0 Cv	3.5 Cv	4.5 Cv	4.7 Cv	7.3 Cv	7.7 Cv	10 Cv
0.5 psi	0.2	0.4	0.5	0.7	0.8	1.4	1.5	2.1	2.5	3.2	3.3	5.2	5.4	7.1
1 psi	0.3	0.6	0.7	1.0	1.2	2.0	2.1	3.0	3.5	4.5	4.7	7.3	7.7	10.0
2 psi	0.4	0.9	1.0	1.4	1.7	2.8	3.0	4.2	4.9	6.4	6.6	10.3	10.9	14.1
3 psi	0.5	1.1	1.2	1.7	2.1	3.5	3.6	5.2	6.1	7.8	8.1	12.6	13.3	17.3
4 psi	0.6	1.3	1.4	2.0	2.4	4.0	4.2	6.0	7.0	9.0	9.4	14.6	15.4	20.0
5 psi	0.67	1.5	1.6	2.2	2.7	4.5	4.7	6.7	7.8	10.1	10.5	16.3	17.2	22.4
6 psi	0.7	1.6	1.7	2.4	2.9	4.9	5.1	7.3	8.6	11.0	11.5	17.9	18.9	24.5
7 psi	0.8	1.8	1.9	2.6	3.2	5.3	5.6	7.9	9.3	11.9	12.4	19.3	20.4	26.5
8 psi	0.85	1.9	2.0	2.8	3.4	5.7	5.9	8.5	9.9	12.7	13.3	20.6	21.8	28.3
9 psi	0.9	2.0	2.1	3.0	3.6	6.0	6.3	9.0	10.5	13.5	14.1	21.9	23.1	30.0
10 psi	0.95	2.1	2.2	3.2	3.8	6.3	6.6	9.5	11.1	14.2	14.9	23.1	24.3	31.6

Flow Characteristics

The VBB/VBS series two- and three-way ball valve assemblies provide equal percentage flow, which is achieved with a flow characterizing insert. The parabolic shape of the orifice allows a gradual change in flow, so that equal movements of the valve stem, at any point of the flow range, change the existing flow an equal percentage, regardless of the flow rate. As shown in the graph to the right a ball valve equipped with the flow insert mirrors the flow characteristic of the coil, resulting in linear heat transfer.

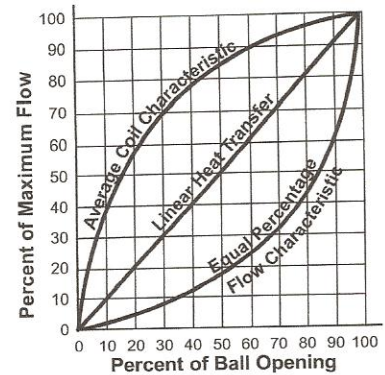
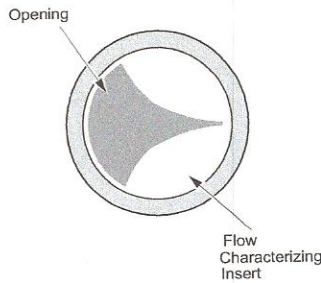

[DuraDrive] VBB/VBS Series Ball Valve Assemblies

Using Pipe Reducers with Ball Valves

This chart provides estimated effective Cvs when using pipe reducers with ball valve assemblies. Use these estimated effective Cv's in place of the rated Cvs when reducers or increasers are located within 6 pipe diameters upstream and 3 pipe diameters downstream of the valve.



Caution
Do not reduce the valve size to less than one-half the line size, as this may weaken the pipe reduction area. Physical injury can result if the weakened piping fails.

Two-Way Valves

Valve Size in (mm)	Valve Body		Cv (Kv)	Estimated Effective Cv (Kv)				
				Pipe Size in Inches				
	NPT Threaded	RP Threaded		1/2	3/4	1	1-1/4	1-1/2
1/2 (15)	VBx2N00	VBx2R00	0.3 (0.3)	0.3 (0.3)	0.3 (0.3)	0.3 (0.3)	-	-
	VBx2N01	VBx2R01	0.7 (0.6)	0.7 (0.6)	0.7 (0.6)	0.7 (0.6)	-	-
	VBx2N02	VBx2R02	1.2 (1.0)	1.2 (1.0)	1.2 (1.0)	1.2 (1.0)	-	-
	VBx2N03	VBx2R03	2.1 (1.8)	2.1 (1.8)	2.1 (1.8)	2.1 (1.8)	-	-
	VBx2N04	VBx2N04	3.5 (3.0)	3.5 (3.0)	3.3 (2.8)	3.1 (2.7)	-	-
	VBx2N05	VBx2N05	4.7 (4.1)	4.7 (4.1)	4.4 (3.8)	4.1 (3.5)	-	-
	VBx2N06	VBx2N06	7.7 (6.7)	7.7 (6.7)	6.6 (5.7)	5.5 (4.8)	-	-
	VBx2N07	VBx2N07	10 (8.7)	10 (8.7)	8.5 (7.4)	7.0 (6.0)	-	-
3/4 (20)	VBx2N10	VBx2R10	0.3 (0.3)	-	0.3 (0.3)	0.3 (0.3)	0.3 (0.3)	0.3 (0.3)
	VBx2N11	VBx2N11	0.7 (0.6)	-	0.7 (0.6)	0.7 (0.6)	0.7 (0.6)	0.7 (0.6)
	VBx2N12	VBx2N12	1.2 (1.0)	-	1.2 (1.0)	1.2 (1.0)	1.2 (1.0)	1.2 (1.0)
	VBx2N13	VBx2N13	2.1 (1.8)	-	2.1 (1.8)	2.1 (1.8)	2.1 (1.8)	2.1 (1.8)
	VBx2N14	VBx2N14	3.5 (3.0)	-	3.5 (3.0)	3.5 (3.0)	3.5 (3.0)	3.5 (3.0)
	VBx2N15	VBx2N15	4.7 (4.1)	-	4.7 (4.1)	4.6 (4.0)	4.5 (3.9)	4.4 (3.8)
	VBx2N16	VBx2N16	7.7 (6.7)	-	7.7 (6.7)	7.5 (6.5)	7.3 (6.3)	7.2 (6.2)
	VBx2N17	VBx2N17	10 (8.7)	-	10 (8.7)	9.5 (8.2)	9.0 (7.8)	7.2 (6.2)

Three-Way Valves

Valve Size in (mm)	Valve Body		Cv (Kv)	Estimated Effective Cv (Kv)				
				Pipe Size in Inches				
	NPT Threaded	RP Threaded		1/2	3/4	1	1-1/4	1-1/2
1/2 (15)	VBx3N00	VBx3R00	0.3 (0.3)	0.3 (0.3)	0.3 (0.3)	0.3 (0.3)	-	-
	VBx3N01	VBx3R01	0.6 (0.5)	0.6 (0.5)	0.6 (0.5)	0.6 (0.5)	-	-
	VBx3N02	VBx3R02	1.0 (.9)	1.0 (.9)	1.0 (.9)	1.0 (.9)	-	-
	VBx3N03	VBx3R03	2.0 (1.7)	2.0 (1.7)	2.0 (1.7)	2.0 (1.7)	-	-
	VBx3N04	VBx3R04	3.0 (2.6)	3.0 (2.6)	2.9 (2.5)	2.8 (2.4)	-	-
	VBx3N05	VBx3R05	4.5 (3.8)	4.5 (3.8)	4.2 (3.6)	3.9 (3.3)	-	-
	VBx3N06	VBx3R06	7.3 (6.2)	7.3 (6.2)	6.2 (5.3)	5.1 (4.4)	-	-
	VBx3N07	VBx3R07	10.0 (8.5)	10.0 (8.5)	8.5 (7.4)	7.0 (6.0)	-	-
3/4 (20)	VBx3N10	VBx3R10	0.3 (0.3)	-	0.3 (0.3)	0.3 (0.3)	0.3 (0.3)	0.3 (0.3)
	VBx3N11	VBx3R11	0.6 (0.5)	-	0.6 (0.5)	0.6 (0.5)	0.6 (0.5)	0.6 (0.5)
	VBx3N12	VBx3R12	1.0 (.9)	-	1.0 (.85)	1.0 (.85)	1.0 (.9)	1.0 (.9)
	VBx3N13	VBx3R13	2.0 (1.7)	-	2.0 (1.7)	2.0 (1.7)	2.0 (1.7)	2.0 (1.7)
	VBx3N14	VBx3R14	3.0 (2.6)	-	3.0 (2.6)	3.0 (2.6)	2.9 (2.5)	2.9 (2.5)
	VBx3N15	VBx3R15	4.5 (3.8)	-	4.5 (3.8)	4.4 (3.8)	4.3 (3.7)	4.2 (3.6)
	VBx3N16	VBx3R16	7.3 (6.2)	-	7.3 (6.2)	7.1 (6.1)	6.9 (5.9)	6.8 (4.1)
	VBx3N17	VBx3R17	10.0 (8.5)	-	10.0 (8.5)	9.5 (8.2)	9.0 (7.8)	7.2 (6.2)

Water System Maintenance

All heating and cooling systems are susceptible to valve and system problems caused by improper water treatment and system storage procedures. The following guidelines are to help avoid valve and water system problems resulting from improperly treated water or storage procedures, and to obtain maximum life from the valves. To maintain non-damaging conditions, clean the system prior to start up. Use a nitrite or molybdate based treatment program. Use filtration equipment where needed. Properly store off-line systems and monitor water treatment results using corrosion test coupons. Durability of valve stems, balls, seats, and packing is dependent on maintaining non-damaging water conditions. Inadequate water treatment or filtration, not in accordance with chemical supplier/ASHRAE handbook recommendations, can result in corrosion, scale, and abrasive particle formation. Scale and particulates can result in stem and packing scratches, and can adversely affect packing life and other parts of the hydronic system. Follow the advice of a water treatment professional. Consult EN-205 Water and Steam System Guidelines, Engineering Information, F-26080, for further details.

Piping

These valves must be piped so the flow is in the direction of the diagrams below. Flow is from A (and/or B) to AB.

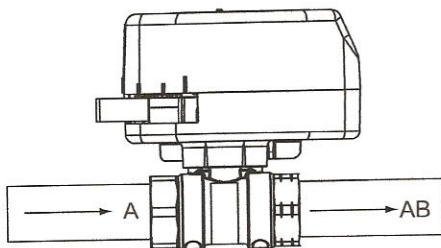

Two-Way Valve: Flow A to AB

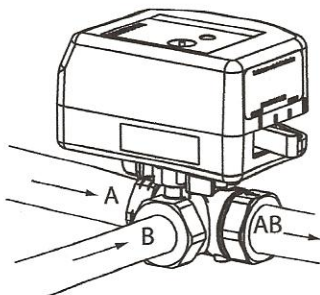

Three-Way Valve: Mixing Only
A and/or B to AB.

Maintenance

The ball valve assembly itself requires no maintenance. The stem and packing design eliminates the need for packing adjustment for the life of the valve. However, regular maintenance of the total heating and cooling system is recommended to ensure sustained optimum performance.

Field Repair

Neither valve nor actuator are field repairable. Replace entire unit as necessary.

Patents

US Patents for VBB/VBS Series Valves and M1/M2 Series Actuators:
5815365, 6044857, 6073907, 7111643, 7131635, 7367544, 7559531.
Other US and foreign patents pending.

Mounting

The valves can be mounted in horizontal or vertical piping. When installed in horizontal piping, the actuator must be above the valve body. When installed in horizontal piping the actuator can be tilted left or right but it must not be tilted below 90° from vertical.

